

SYSTEM WIRING DIAGRAMS

Defogger Circuit

1990 Isuzu Trooper

For x

Copyright © 1998 Mitchell Repair Information Company, LLC

Monday, September 06, 2004 11:12PM

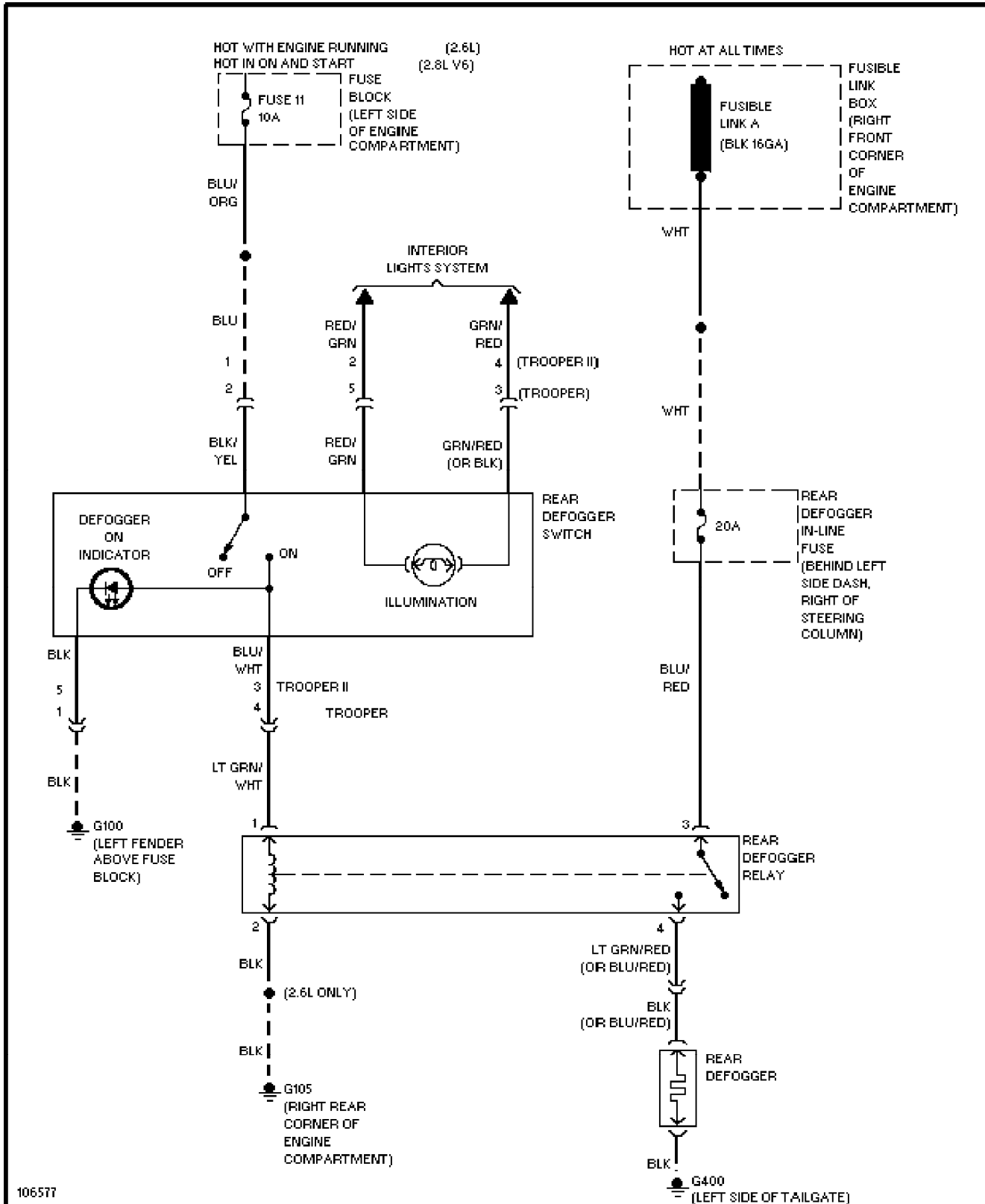

SYSTEM WIRING DIAGRAMS

Horn Circuit (p. 2)

1990 Isuzu Trooper

For x

Copyright © 1998 Mitchell Repair Information Company, LLC
Monday, September 06, 2004 11:12PM

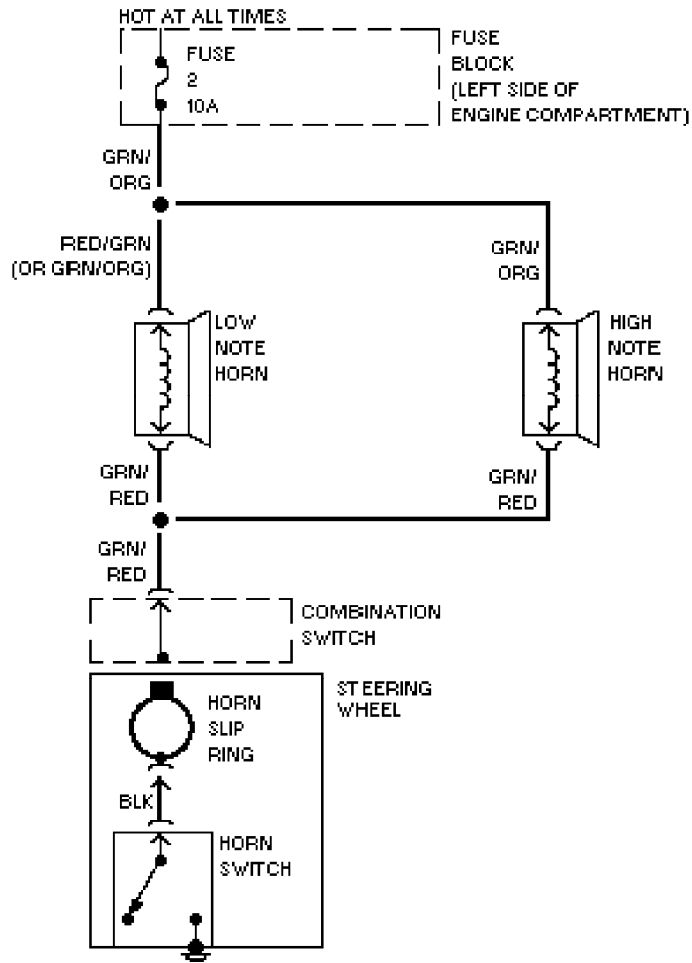

SYSTEM WIRING DIAGRAMS

Power Door Lock Circuit (p. 3)

1990 Isuzu Trooper

For x

Copyright © 1998 Mitchell Repair Information Company, LLC
 Monday, September 06, 2004 11:12PM

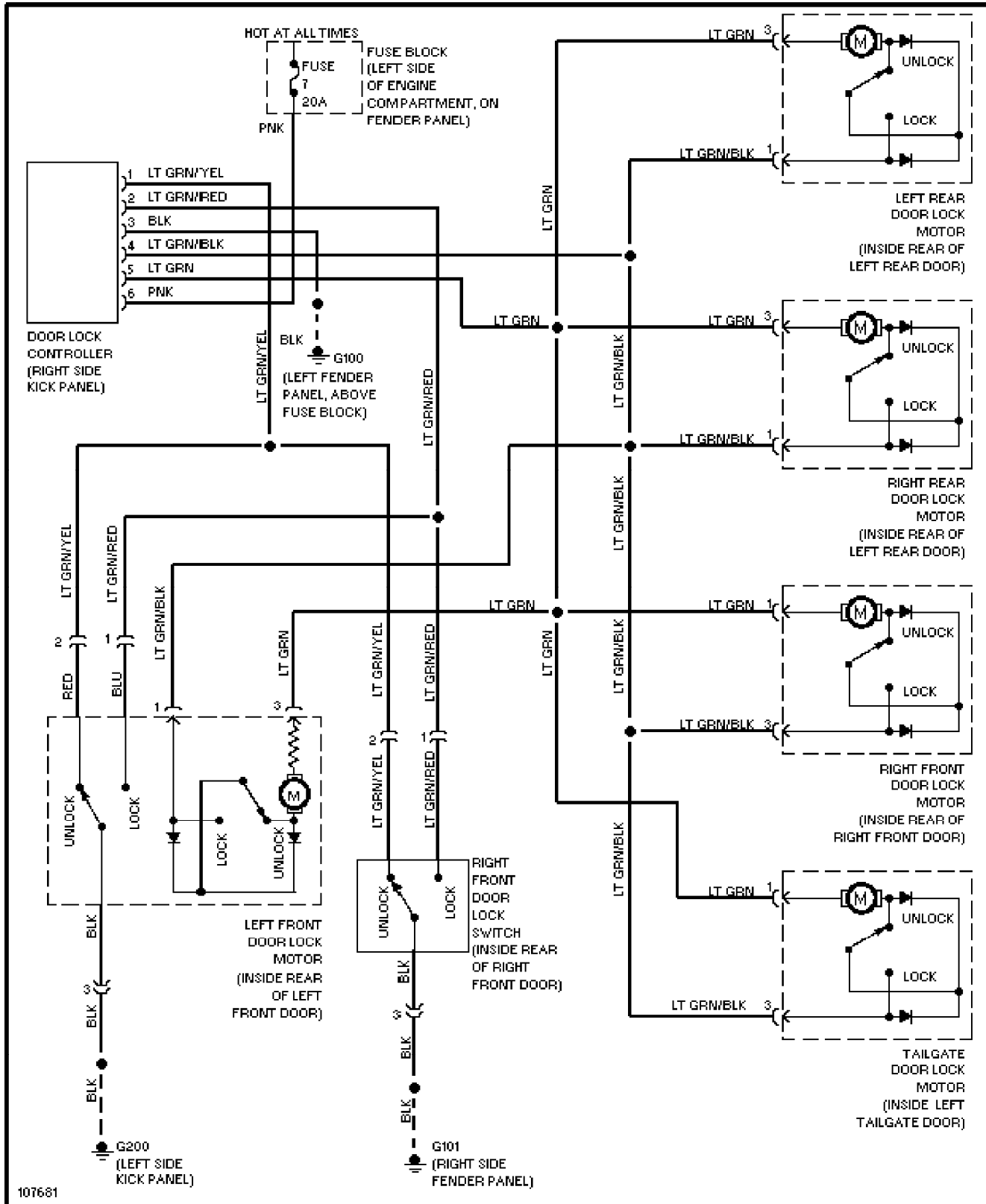

SYSTEM WIRING DIAGRAMS

Power Window Circuit (p. 4)

1990 Isuzu Trooper

For x

Copyright © 1998 Mitchell Repair Information Company, LLC

Monday, September 06, 2004 11:12PM

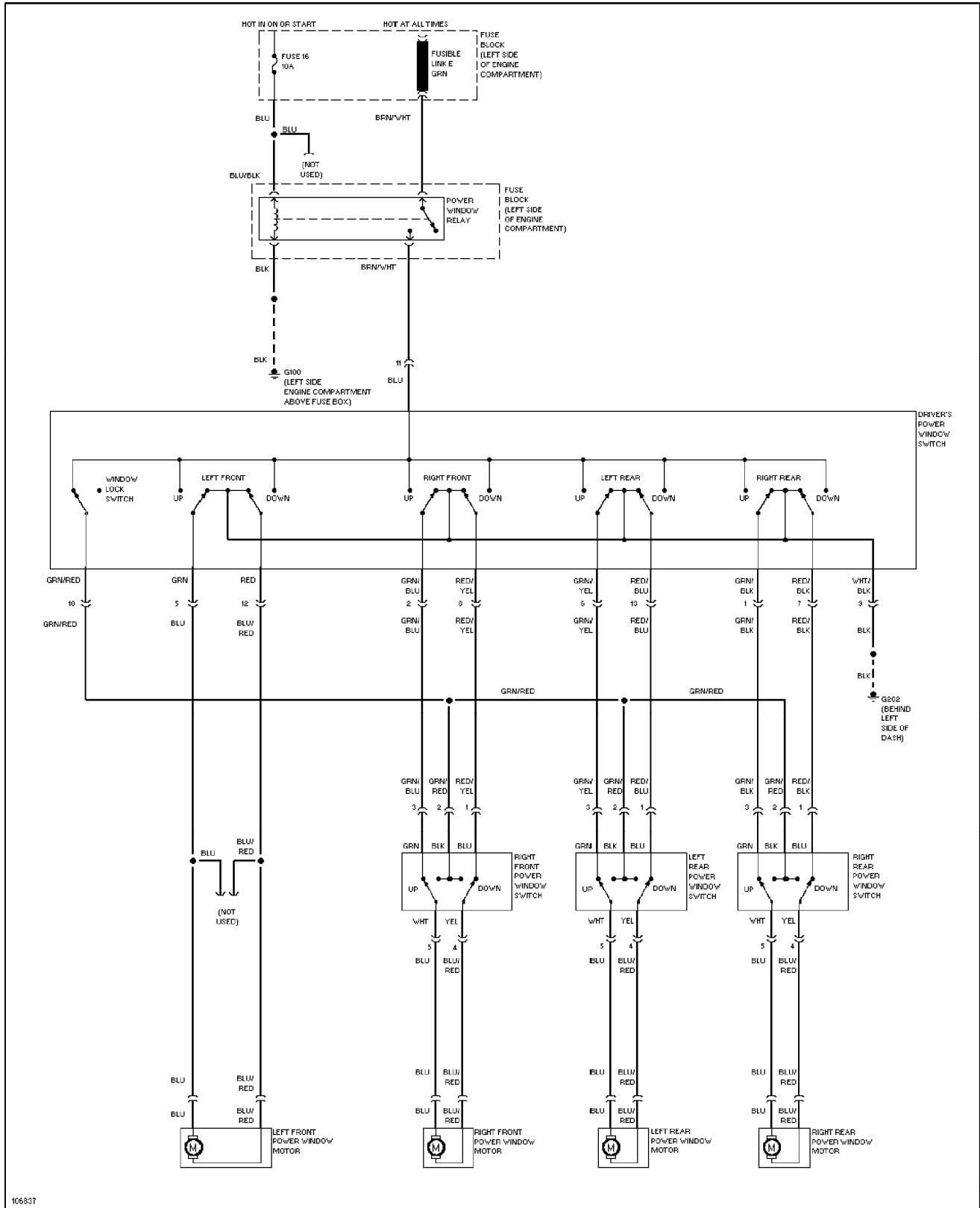

SYSTEM WIRING DIAGRAMS

Radio Circuits (p. 5)

1990 Isuzu Trooper

For x

Copyright © 1998 Mitchell Repair Information Company, LLC

Monday, September 06, 2004 11:12PM

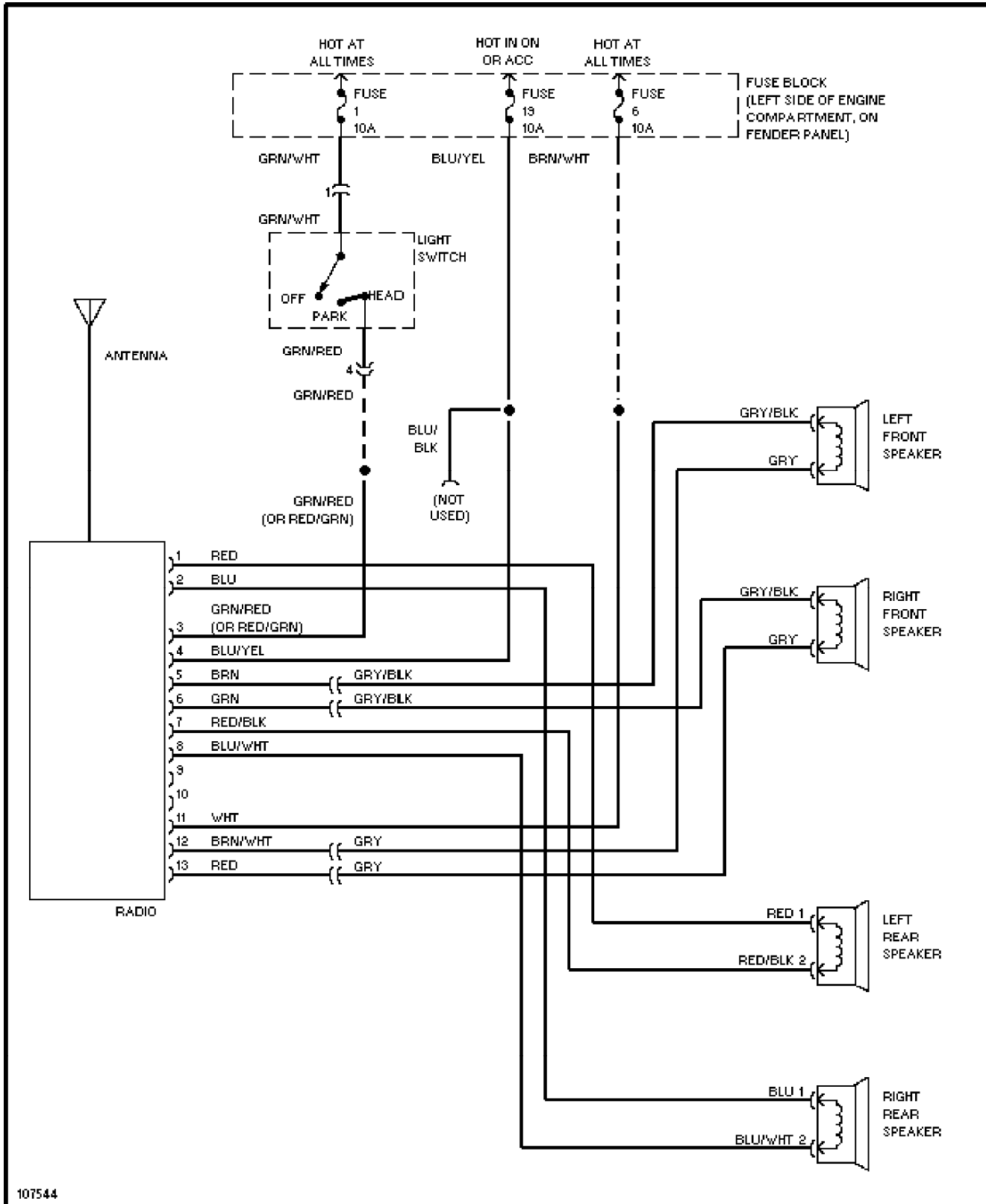

SYSTEM WIRING DIAGRAMS

2.6L, Charging Circuit (p. 6)

1990 Isuzu Trooper

For x

Copyright © 1998 Mitchell Repair Information Company, LLC

Monday, September 06, 2004 11:12PM

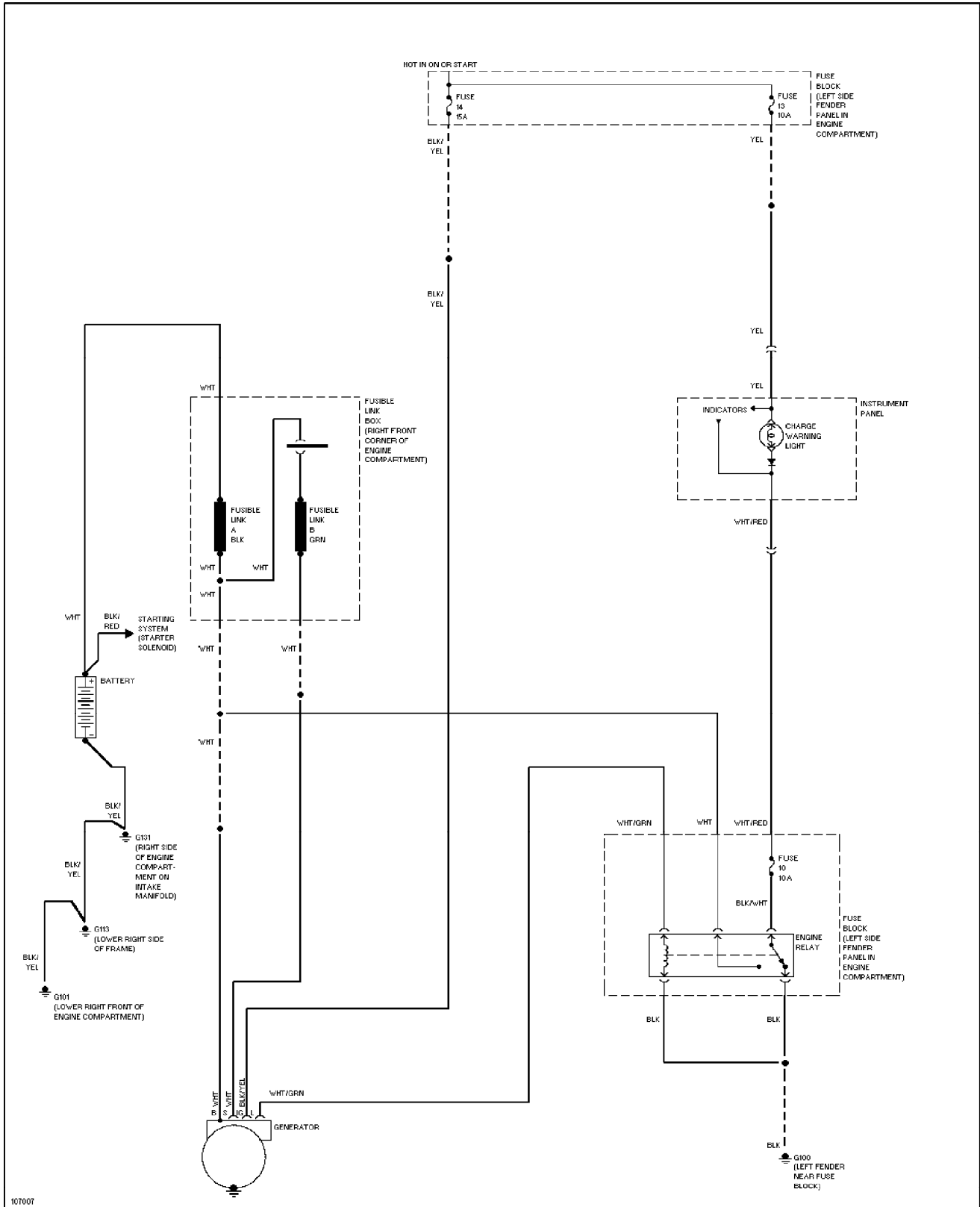

SYSTEM WIRING DIAGRAMS

2.6L, Starting Circuit (p. 7)

1990 Isuzu Trooper

For x

Copyright © 1998 Mitchell Repair Information Company, LLC

Monday, September 06, 2004 11:12PM

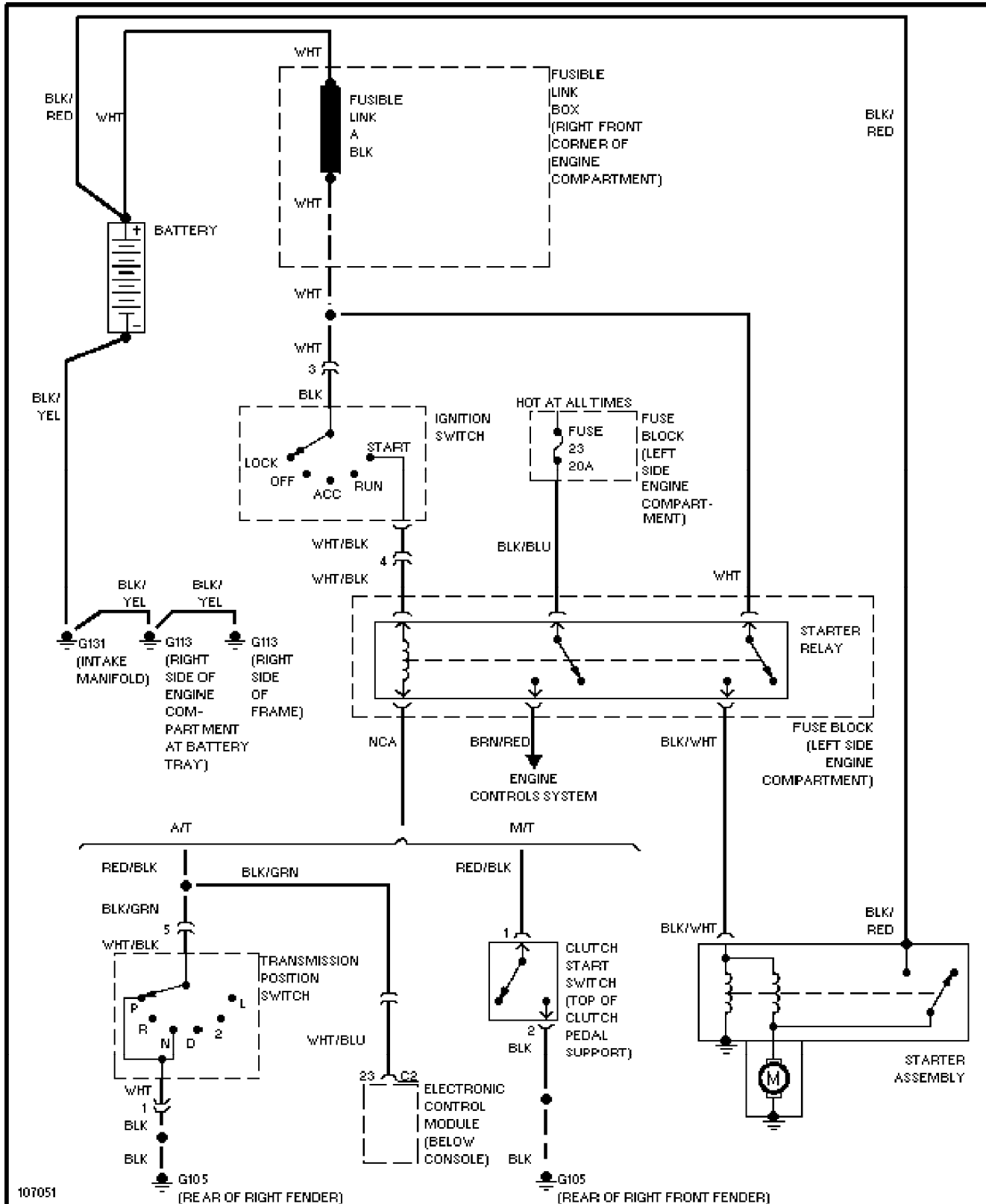

SYSTEM WIRING DIAGRAMS

2.8L, Charging Circuit (p. 8)

1990 Isuzu Trooper

For x

Copyright © 1998 Mitchell Repair Information Company, LLC

Monday, September 06, 2004 11:12PM

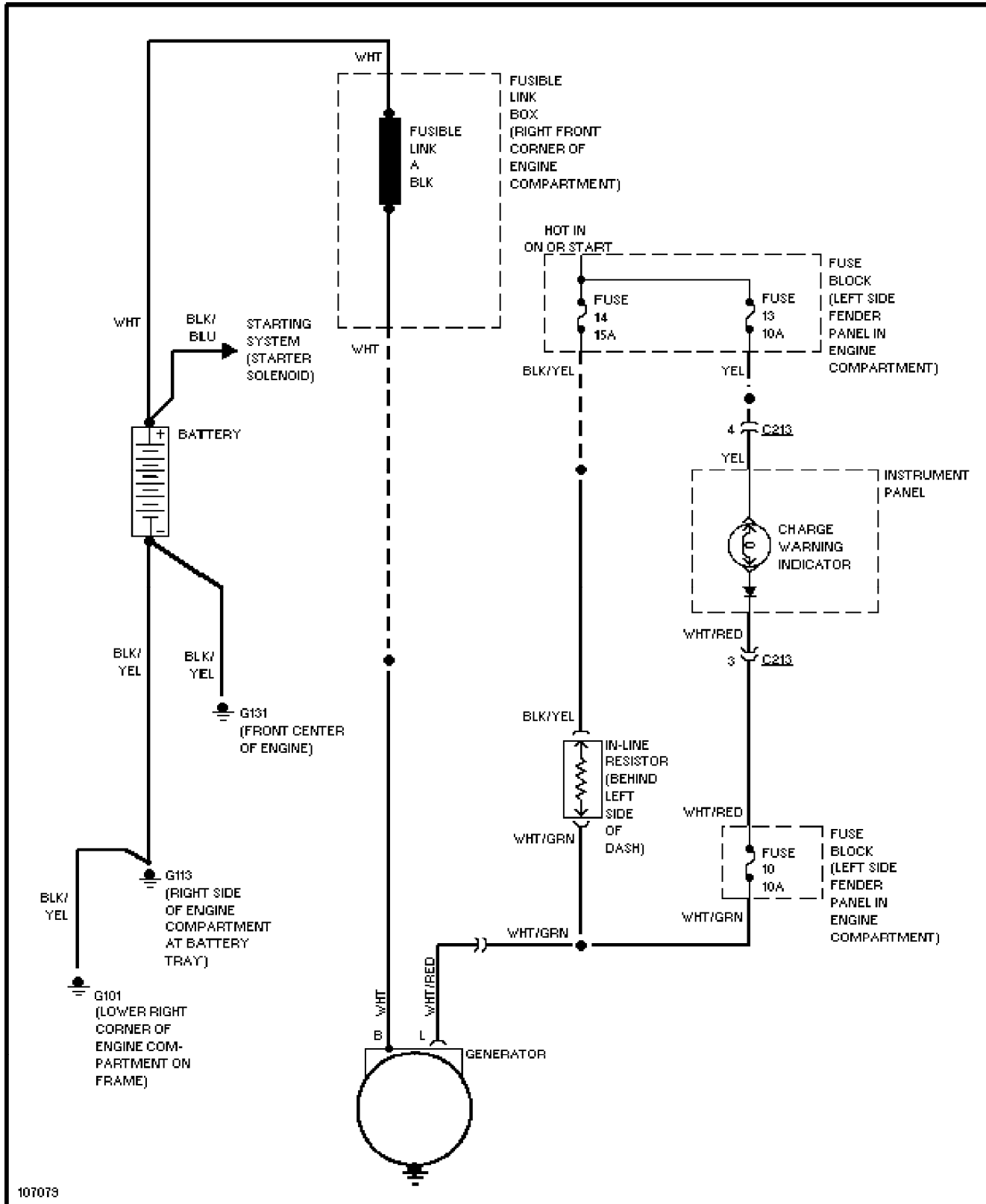

SYSTEM WIRING DIAGRAMS

2.8L, Starting Circuit (p. 9)

1990 Isuzu Trooper

For x

Copyright © 1998 Mitchell Repair Information Company, LLC

Monday, September 06, 2004 11:12PM

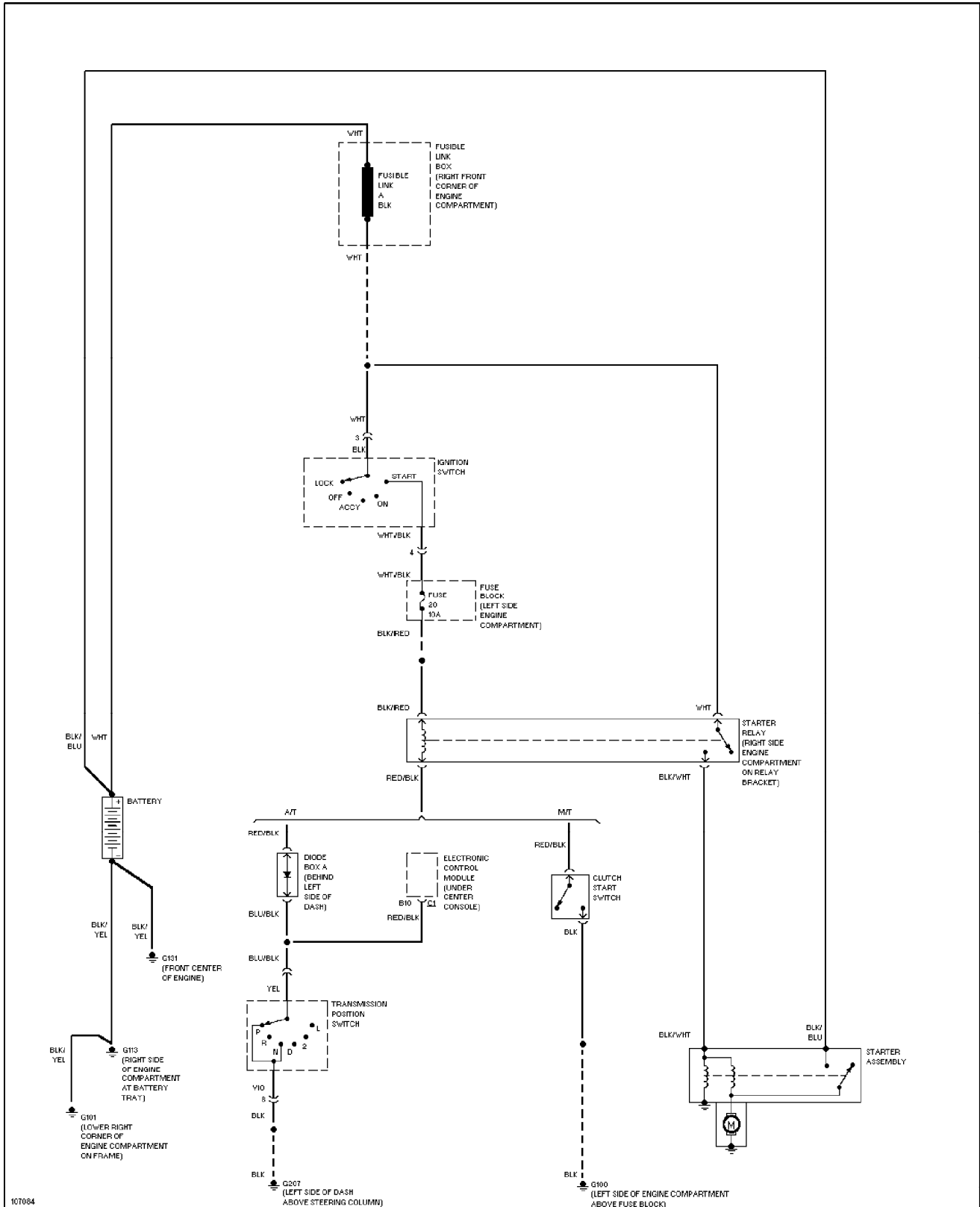

SYSTEM WIRING DIAGRAMS

Front Washer/Wiper Circuit (p. 10)

1990 Isuzu Trooper

For x

Copyright © 1998 Mitchell Repair Information Company, LLC
Monday, September 06, 2004 11:12PM

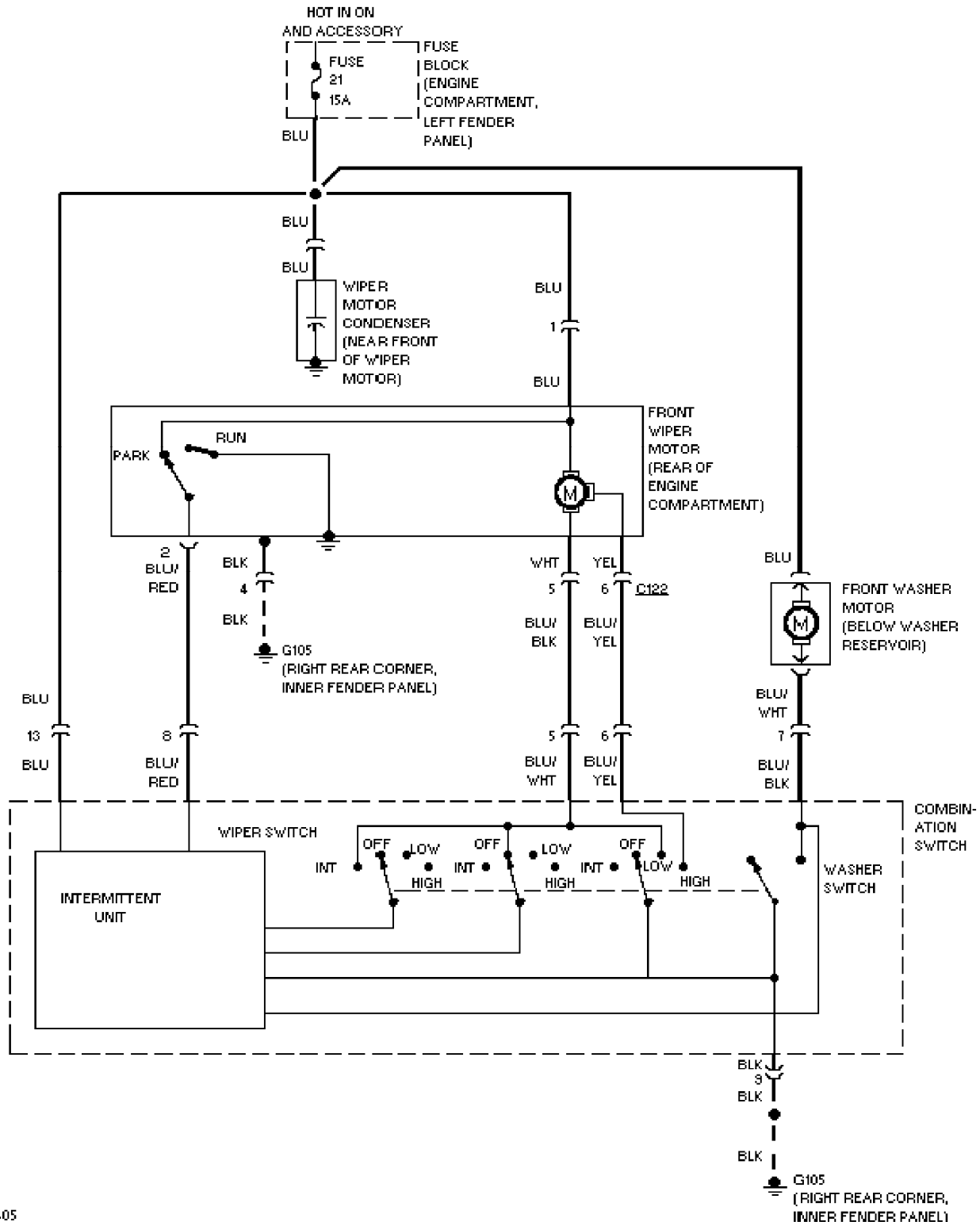

SYSTEM WIRING DIAGRAMS

Rear Washer/Wiper Circuit (p. 11)

1990 Isuzu Trooper

For x

Copyright © 1998 Mitchell Repair Information Company, LLC
Monday, September 06, 2004 11:12PM

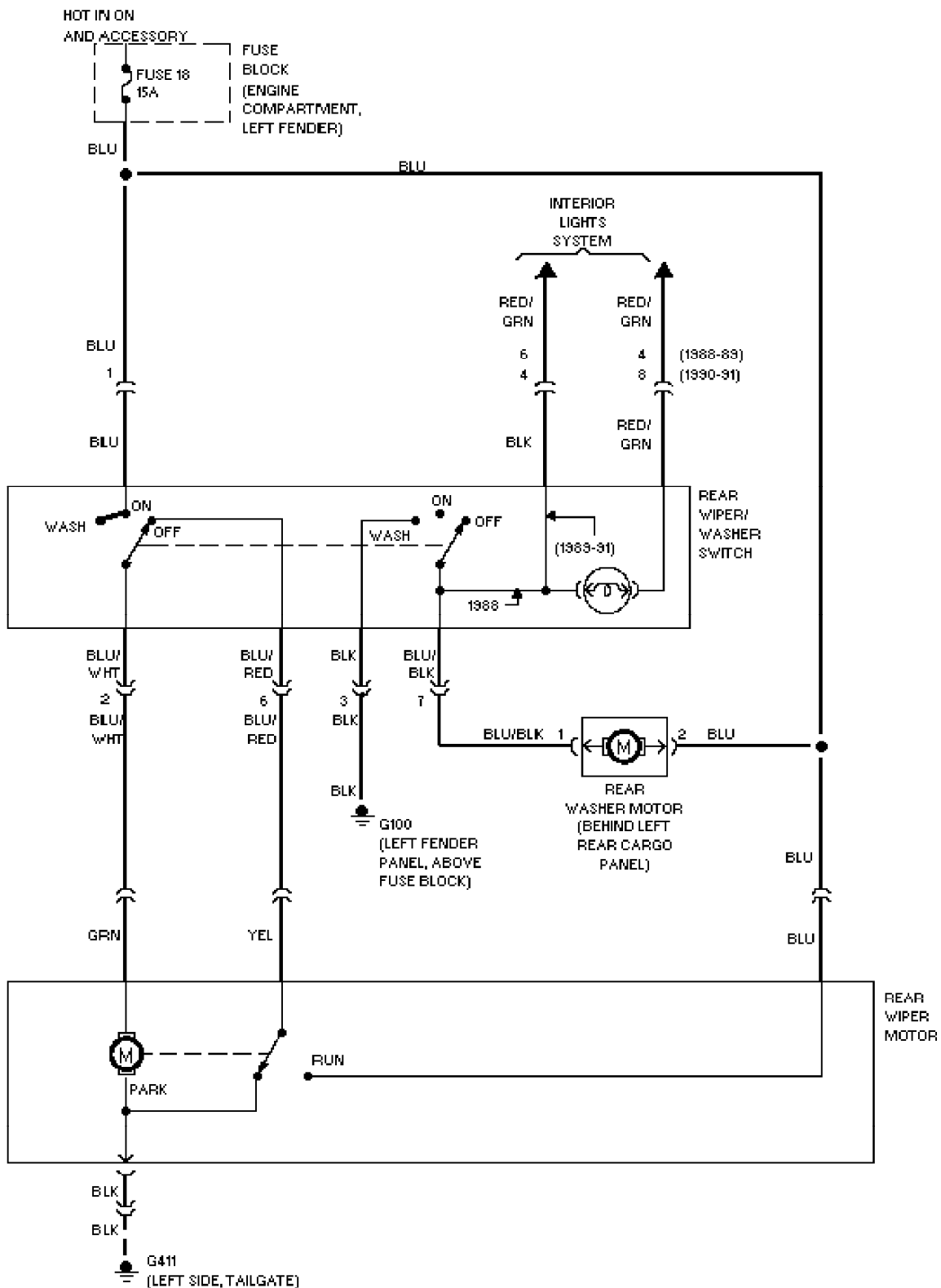

WIRING DIAGRAMS

Fig. 1: Engine Compartment & Headlights (Grids 1-3)

1990 Isuzu Trooper

For x

Copyright © 1998 Mitchell Repair Information Company, LLC

Monday, September 06, 2004 11:17PM

COMPONENT LOCATOR:

A/C BLOWER RLY	A-8 27
A/C COMP CUTOFF RLY #2	D-E 27
A/C DUAL PRES SW	C-D 26
ALTERNATOR (4 CYL)	E 3
ALTERNATOR (V6)	C 2
BACK-UP LT SW (M/T)	A 34
BEAM SEL SW	C-D 12
BRAKE SW	E-28
CHIME MODULE	C 12
OIG LTR	C 12
CLUTCH SW	D 19
CONSOLE WARN LT ASSY (4 CYL)	C 23
CONSOLE WARN LT ASSY (V6)	B 19
CRUISE CTRL SW	E 16
CRUISE CTRL UNIT	D 16
DEFOG RLY	D 35
DEFOG SW	D 35
DIR LT SW	D 12
DOME LT	C 32
DOOR LOCK CTRL	E 32
ELECTRONIC CONTROL MODULE (2.8L 4 CYL)	A-C 4
ELECTRONIC CONTROL MODULE (2.8L V6)	A 6-11
ELECTRONIC TRANS CTRL UNIT (4 CYL)	D-E 23
ELECTRONIC TRANS CTRL UNIT (V6)	A-C 13
ENGINE RLY (4 CYL)	E 3
ETC DIAG CONN (V6)	A 17
FUEL PUMP BACK-UP RLY	E 3
FUEL PUMP RLY (4 CYL)	D 5
FUEL PUMP RLY (V6)	D 5
FUS LINK BOX	A-E 2
FUSE BLOCK	B-D 13-14
GEAR SEL SW	A-E 20
HEATER-A/C SW	A-E 24
HI BEAM HEADLT RLY	D 7
GN COIL (4 CYL)	D 10
GN COIL (V6)	D 10
IGN KEY SW	E 29
IGNITION SW	A 12-13
INST-CLSTR	A-D 28-29
LIGHT SW	E 12
LOW BEAM HEADLT RLY	C 1
MAIN RLY (4 CYL)	A 7
MAIN RLY (V6)	B 8
OIL PRES SW	D-C 31
PATTERN SEL SW (4 CYL)	B-C 23
PATTERN SEL SW (V6)	A 19
POWER WDO MAIN SW	A 32-33
POWER WDO RLY	B 34
REAR DOME LT	C 33-34
REAR HEATER SW	E 35
REAR WIPER/WASHER SW	C 35
REAR WIPER/WASHER SW LT	C 35
SPEED SENS (4 CYL)	E 21
SPEED SENS (V6)	E 19
STARTER	A 3
STARTER RLY (4 CYL)	B 3
STARTER RLY (V6)	A 3
THROTTLE POSTN SENS (4 CYL)	D 4
TRANS POSTN SW (4 CYL)	E 20-21
TRANSFER POSTN SW	A 30
WARN LIGHT RLY	A 15-14
WIPER MOTOR	D-E 28

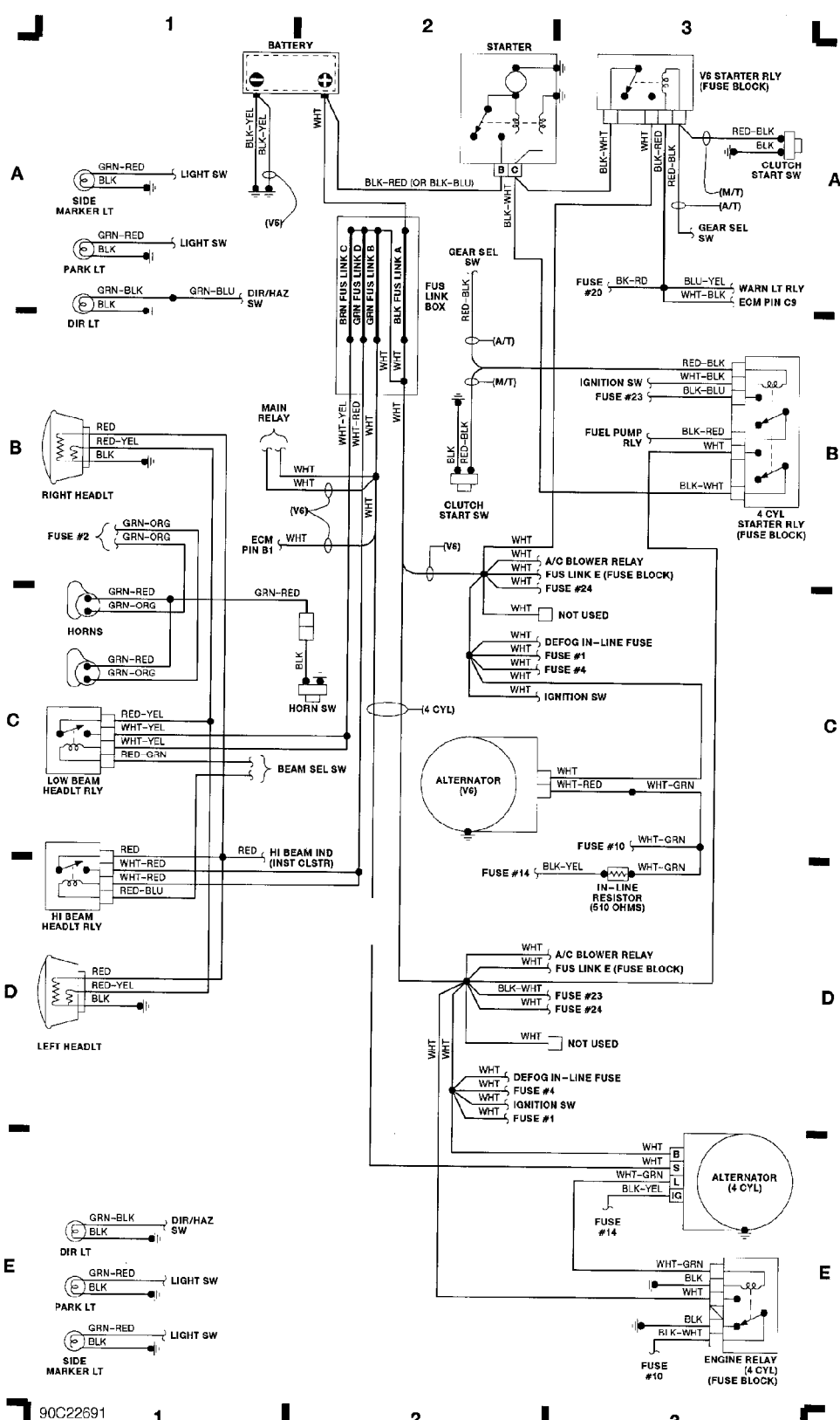

WIRING DIAGRAMS

Fig. 2: Computer Engine Control (2.6L 4-Cyl) (Grids 4-7) (p. 2)

1990 Isuzu Trooper

For x

Copyright © 1998 Mitchell Repair Information Company, LLC

Monday, September 06, 2004 11:17PM

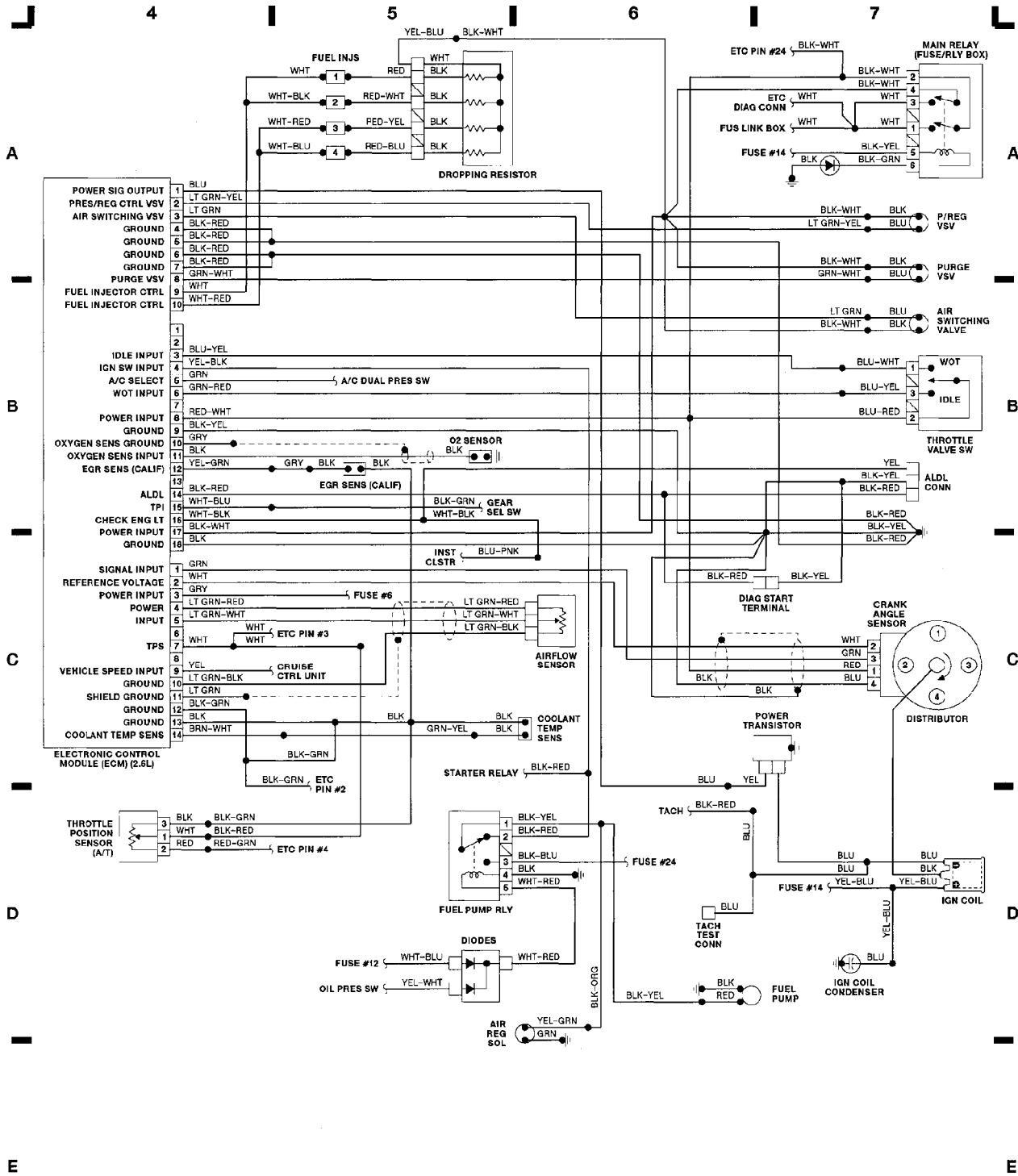

WIRING DIAGRAMS
Fig. 3: Computer Engine Control (2.8L V6) (Grids 8-11) (p. 3)
 1990 Isuzu Trooper
 For x
 Copyright © 1998 Mitchell Repair Information Company, LLC
 Monday, September 06, 2004 11:17PM

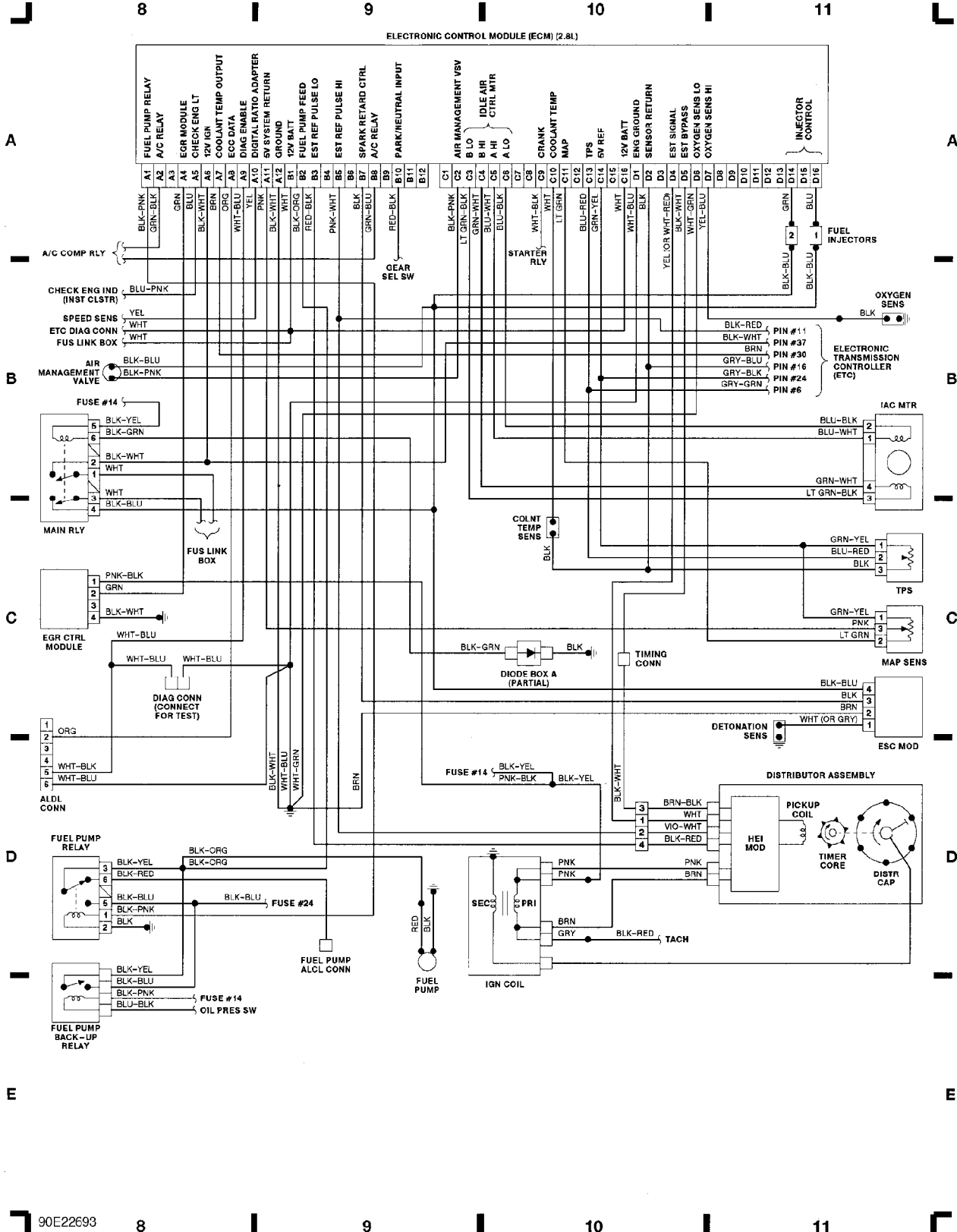

WIRING DIAGRAMS

Fig. 4: Fuse/Relay Block, Ignition Switch (Grids 12-15) (p. 4)

1990 Isuzu Trooper

For x

Copyright © 1998 Mitchell Repair Information Company, LLC

Monday, September 06, 2004 11:17PM

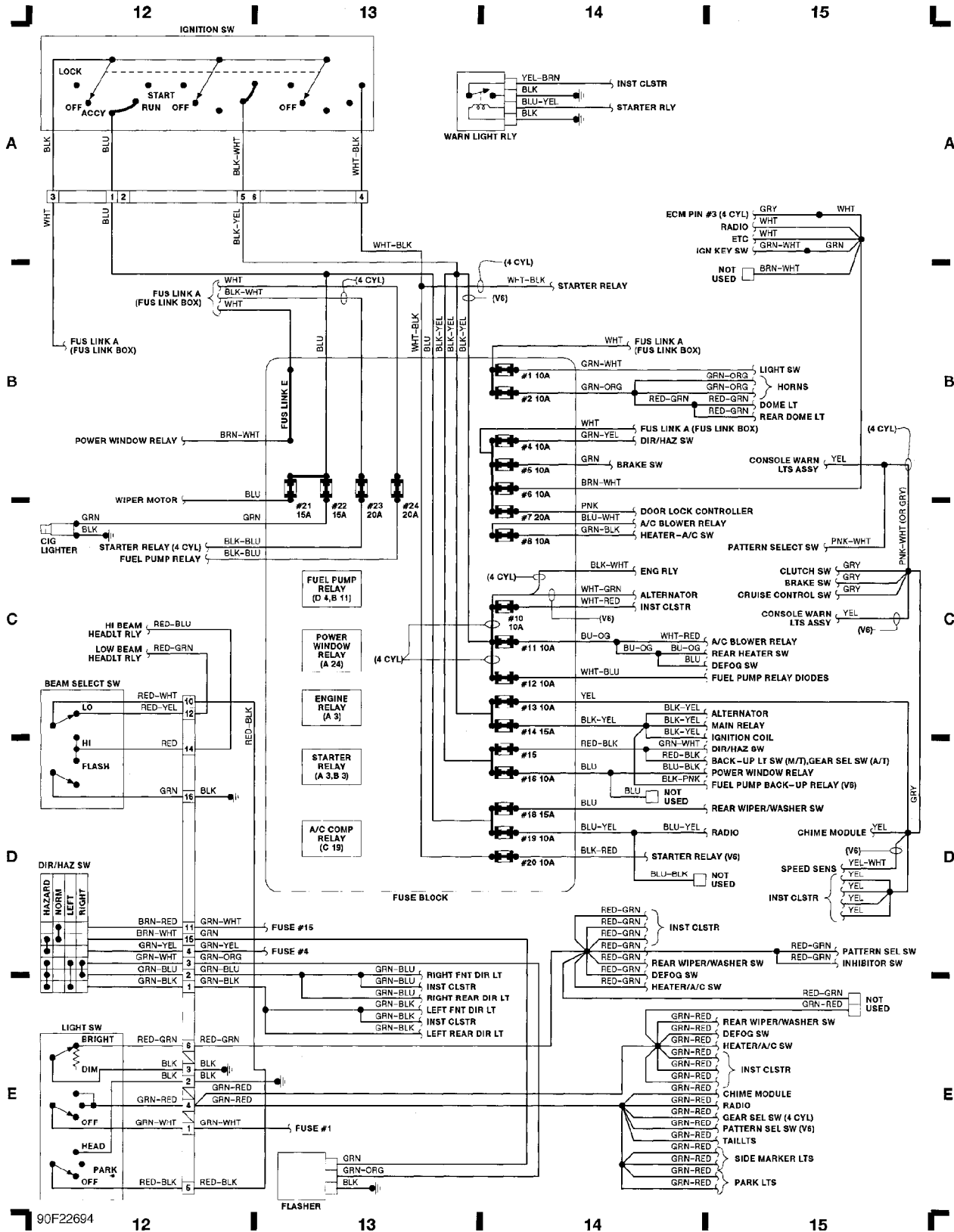

WIRING DIAGRAMS

Fig. 5: Elect Trans Ctrl Unit (2.8L), Cruise Control (Grids 16-19) (p. 5)

1990 Isuzu Trooper

For x

Copyright © 1998 Mitchell Repair Information Company, LLC

Monday, September 06, 2004 11:17PM

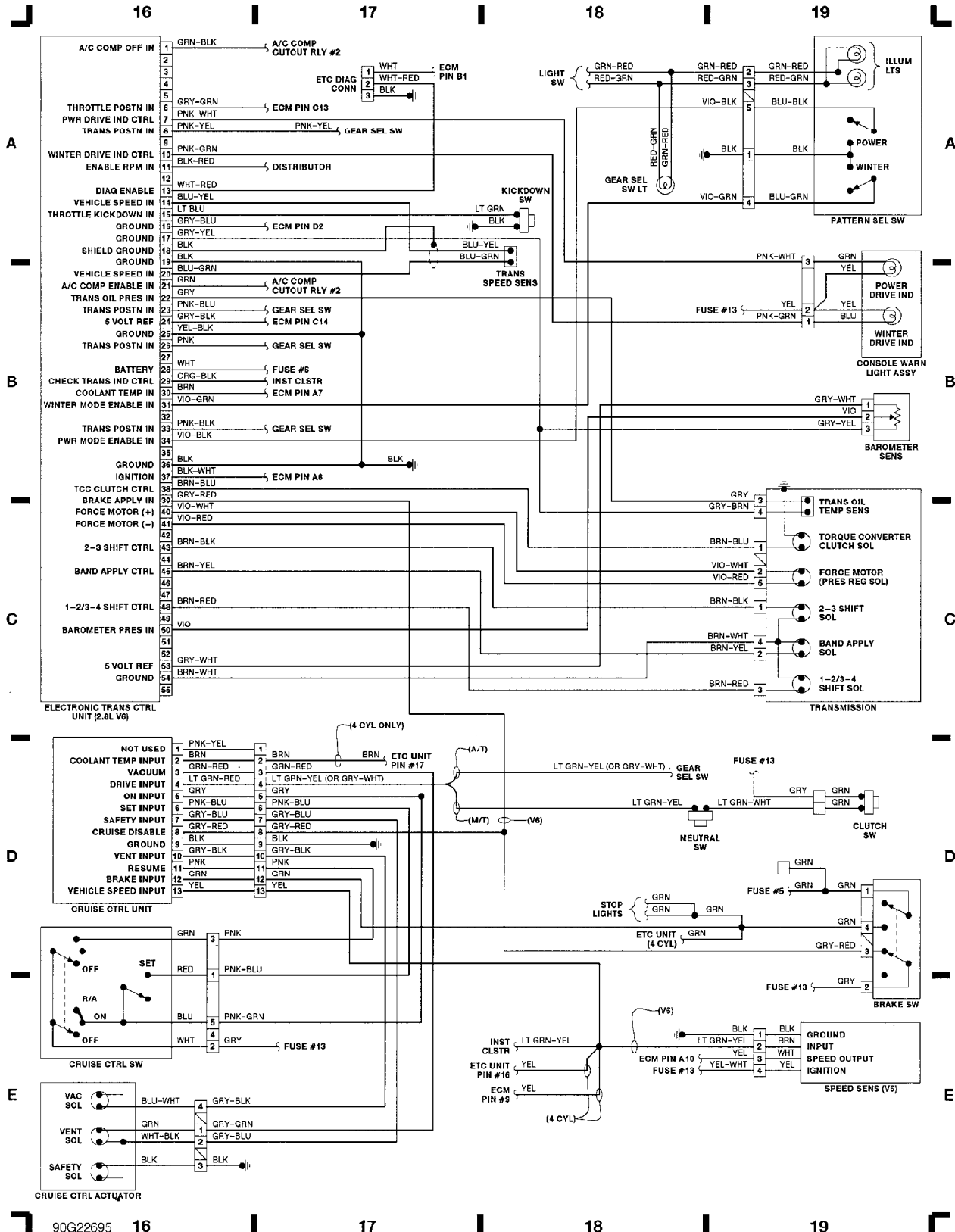

WIRING DIAGRAMS

Fig. 6: Elect Trans Ctrl Unit (2.6L), Gear Select Switch (Grids 20-23) (p. 6)

1990 Isuzu Trooper

For x

Copyright © 1998 Mitchell Repair Information Company, LLC

Monday, September 06, 2004 11:17PM

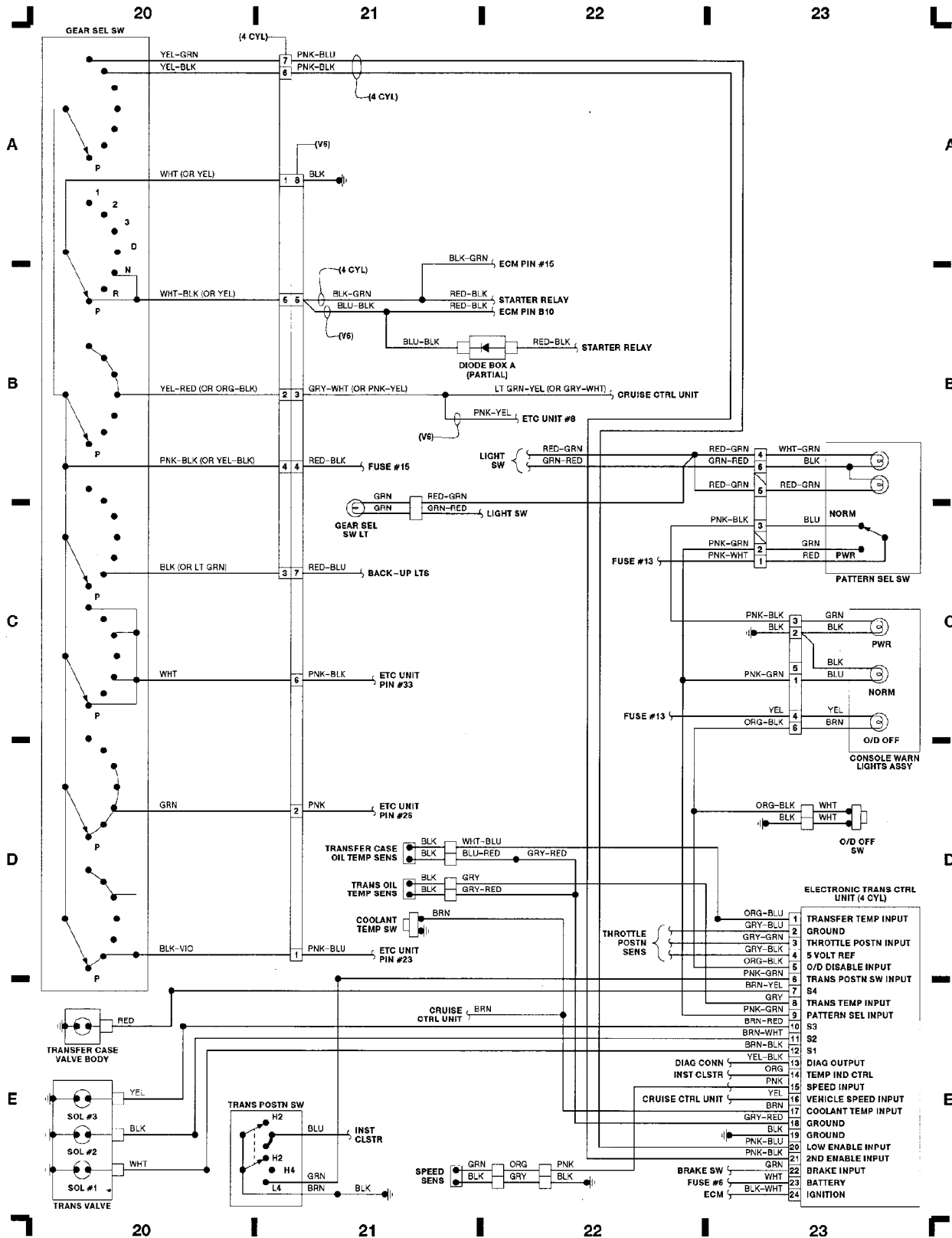

WIRING DIAGRAMS
Fig. 7: A/C Heating System (Grids 24-27) (p. 7)
 1990 Isuzu Trooper
 For x
 Copyright © 1998 Mitchell Repair Information Company, LLC
 Monday, September 06, 2004 11:17PM

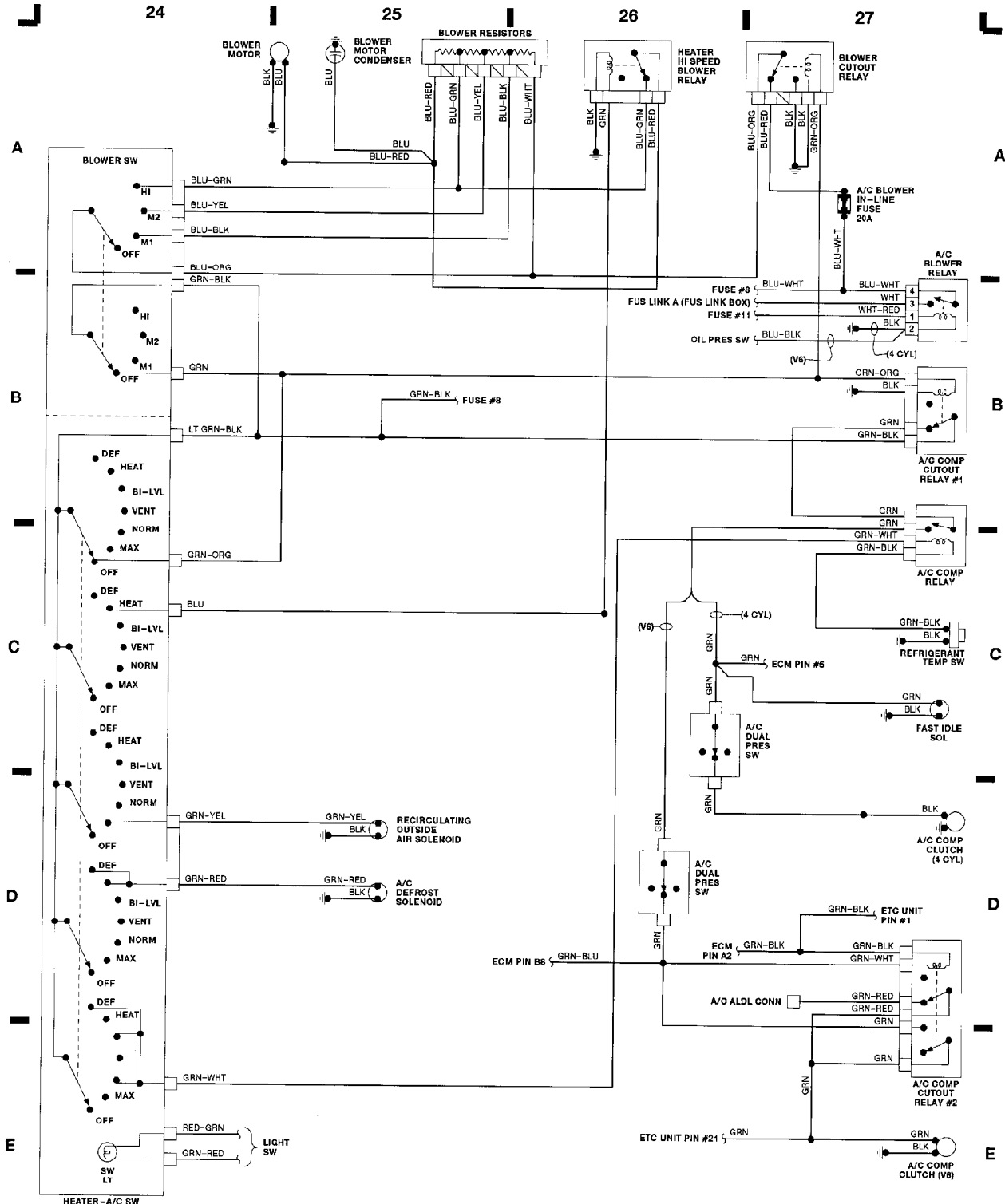

WIRING DIAGRAMS

Fig. 8: Instrument Panel, Washer/Wiper (Grids 28-31) (p. 8)

1990 Isuzu Trooper

For x

Copyright © 1998 Mitchell Repair Information Company, LLC

Monday, September 06, 2004 11:17PM

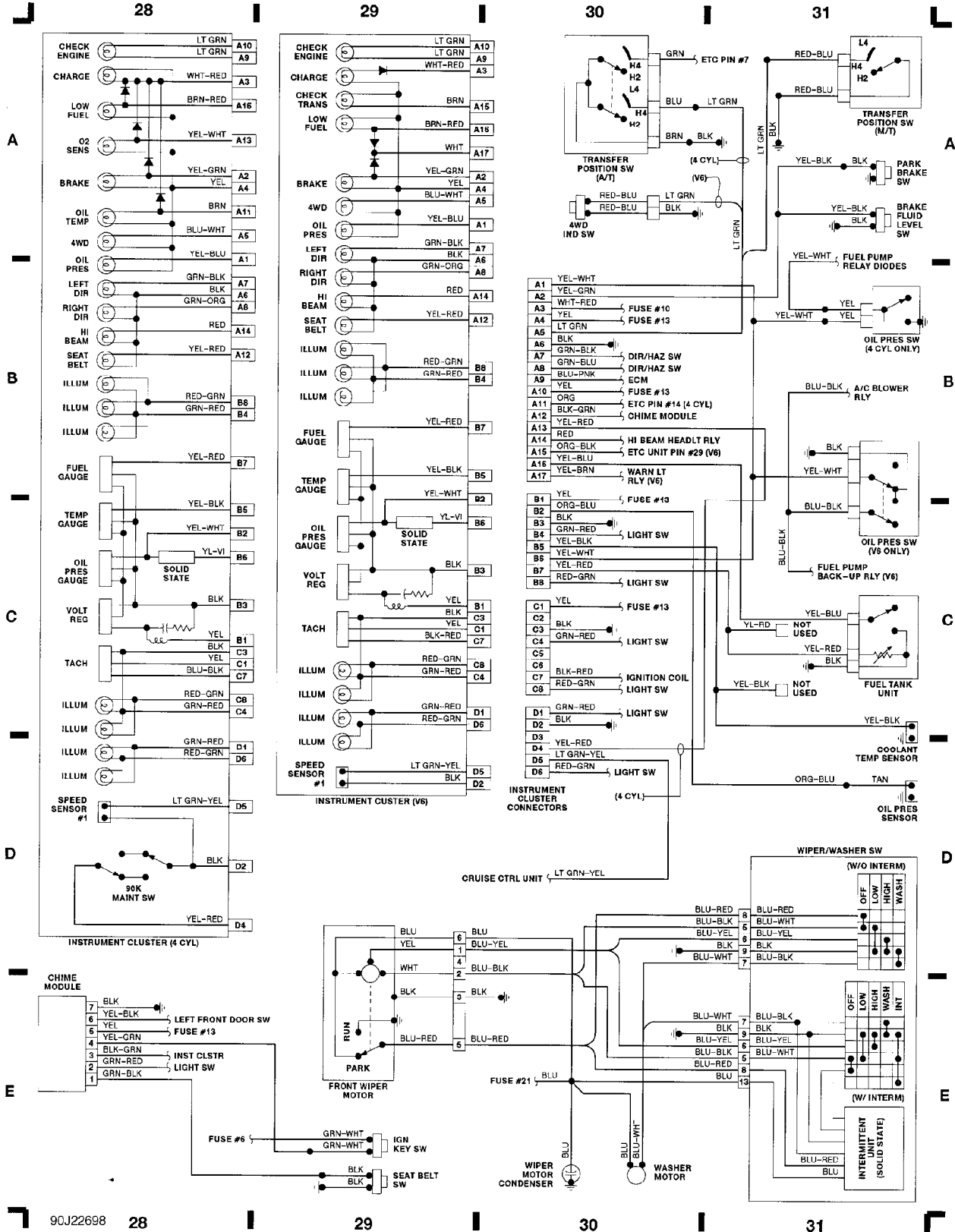

WIRING DIAGRAMS

Fig. 9: Power Door Locks/Window, Taillights (Grids 32-35) (p. 9)

1990 Isuzu Trooper

For x

Copyright © 1998 Mitchell Repair Information Company, LLC

Monday, September 06, 2004 11:17PM

